

1. SCOPE

1.1 Scope. This drawing describes the requirements for tantalum hybrid capacitors, hermetically sealed in welded tantalum case with glass to metal anode terminal.

1.2 General. The capacitor shall utilize a sintered tantalum anodes and ruthenium oxide coated cathodes operating in aqueous electrolyte. The components shall be hermetically sealed in a welded tantalum case with a glass-to-metal anode terminal seal.

1.3 Part or Identifying Number (PIN). The complete PIN is as follows:

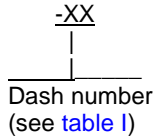
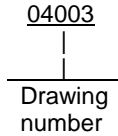

2. APPLICABLE DOCUMENTS

2.1 General. The documents listed in this section are specified in sections 3 and 4 of this specification. This section does not include documents cited in other sections of this specification or recommended for additional information or as examples. While every effort has been made to ensure the completeness of this list, document users are cautioned that they must meet all specified requirements of documents in sections 3 and 4 of this specification, whether or not they are listed.

2.2 Government documents.

2.2.1 Specifications, standards, and handbooks. The following specifications, standards, and handbooks form a part of this document to the extent specified herein. Unless otherwise specified, the issues of these documents are those cited in the solicitation or contract.

STANDARDS

DEPARTMENT OF DEFENSE

- MIL-STD-202 - Test Methods for Electronic and Electrical Components Parts.
- MIL-STD-1285 - Marking of Electrical and Electronic Parts.

(Copies of these documents are available online at <http://assist.daps.dla.mil/quicksearch/> or <http://assist.daps.dla.mil> or from the Standardization Document Order Desk, 700 Robbins Avenue, Building 4D, Philadelphia, PA 19111-5094.)

2.2 Order of precedence. In the event of a conflict between the text of this document and the references cited herein, the text of this document takes precedence. Nothing in this document, however, supersedes applicable laws and regulations unless a specific exemption has been obtained.

DEFENSE SUPPLY CENTER, COLUMBUS COLUMBUS, OHIO	SIZE A	CODE IDENT NO. 037Z3	DWG NO. 04003
		REV C	PAGE 2

3. REQUIREMENTS

3.1 Interface and physical dimensions. The interface and physical dimensions shall be as specified herein (see [figure 1](#)).

3.1.1 Case. The case shall be tantalum.

3.1.2 Mass. 10 - 50 volt parts: 81 ± 3 grams; 63 - 150 volt parts: 99 ± 3 grams.

3.1.3 Pure tin. The use of pure tin as an underplate or final finish is prohibited both internally and externally. Tin content of capacitor components and solder shall not exceed 97 percent by mass. Tin shall be alloyed with a minimum of 3 percent lead, by mass (see [6.3](#))

3.1.4 Storage temperature. The storage temperature shall be -62°C to $+130^{\circ}\text{C}$.

3.1.5 Operating temperature range. The operating temperature range shall be -55°C to $+85^{\circ}\text{C}$ or $[+125^{\circ}\text{C}$ with voltage de-rating ([table I](#))].

3.2 Electrical characteristics.

3.2.1 Rated voltage. The rated voltage shall be in accordance with table I at -55°C to $+85^{\circ}\text{C}$ or $[+125^{\circ}\text{C}$ with voltage derating ([table I](#))].

3.2.2 Surge voltage. The test shall be 1000 cycles at 110% of rated voltage at $85^{\circ}\text{C} \pm 3^{\circ}\text{C}$. Each cycle shall consist of a 30 ± 2 second surge voltage application followed by 330 ± 2 second discharge period. The part shall be charged and discharged through a 1000 ohm resistor. The capacitor must not be visibly damaged and the electrical characteristics must remain within specification.

3.2.3 Dielectric. The dielectric shall be an aqueous electrolyte.

3.2.4 DC leakage current. The maximum DC leakage current shall be as specified in [Table I](#) following 5 minutes at the working voltage and 25°C (see [table II](#)).

3.2.5 Capacitance. Capacitance shall be as specified in [table I](#) at 120 Hz and 25°C , ± 20 percent.

3.2.6 Capacitance tolerance. The capacitance tolerance shall be ± 20 percent at $+25^{\circ}\text{C}$.

3.2.7 Equivalent series resistance (ESR). The maximum equivalent series resistance shall be as specified in [table I](#) at 1 kHz and 25°C .

DEFENSE SUPPLY CENTER, COLUMBUS COLUMBUS, OHIO	SIZE A	CODE IDENT NO. 037Z3	DWG NO. 04003
		REV C	PAGE 3

TABLE I. Electrical characteristics.

DSCC drawing 04003-	Capacitance in (μ F)	85°C rated voltage dc	125°C rated voltage dc	ESR max (ohms)	Leakage current max (μ A)
01	150,000	10	6	0.025	300
02	90,000	16	9.5	0.025	300
03	54,000	25	15	0.035	300
04	36,000	35	20	0.035	300
05	24,000	50	30	0.035	400
06	12,000	63	38	0.035	400
07	8,200	80	48	0.040	500
08	5,700	100	60	0.050	500
09	4,500	110	65	0.075	500
10	3,300	125	75	0.075	500

DEFENSE SUPPLY CENTER, COLUMBUS COLUMBUS, OHIO	SIZE A	CODE IDENT NO. 037Z3	DWG NO. 04003
		REV C	PAGE 4

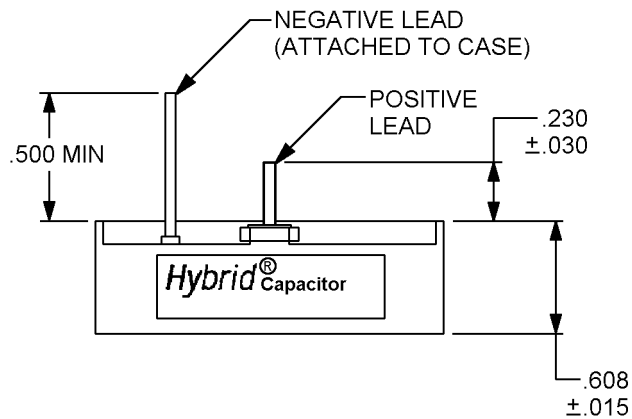
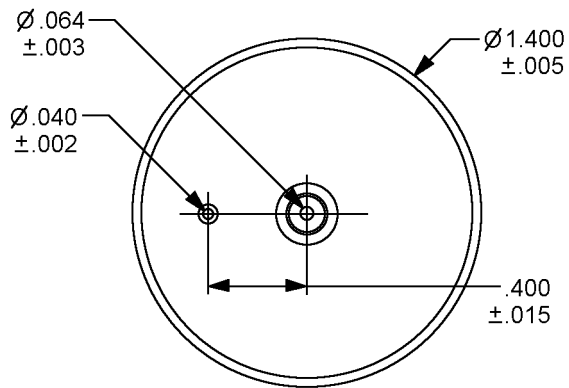

Inches	mm
.002	0.05
.003	0.08
.005	0.13
.015	0.38
.030	0.76
.040	1.02
.064	1.63
.230	5.84
.400	10.16
.500	12.70
.608	15.44
1.400	35.56

NOTES:

1. Dimensions are in inches.
2. Metric equivalents are given for general information only.

FIGURE 1. Case dimensions and configuration.

DEFENSE SUPPLY CENTER, COLUMBUS COLUMBUS, OHIO	SIZE A	CODE IDENT NO. 037Z3	DWG NO. 04003
		REV C	PAGE 5

3.3 Environmental testing.

TABLE II. Environmental testing.

Test	Test method	Condition	Details
Shock	MIL-STD-202, method 213	G	11 mS at 50 g
Vibration	MIL-STD-202, method 204	D	12 sweeps/axis, 20 g peak
Vibration	MIL-STD-202, method 214	I, letter D	1.5 hours/axis, 12 g rms
Moisture resistance	MIL-STD-202, method 106		6 V polarity
Thermal shock	MIL-STD-202, method 107	A	
Altitude	MIL-STD-202, method 105	D	100,000 ft test

3.3.1 Thermal shock. Thermal shock test shall be as specified in [table II](#).

3.3.2 Moisture resistance. Moisture resistance test shall be as specified in [table II](#).

3.3.3 Hermetic seal. The capacitor shall be hermetically sealed such that the case does not leak electrolyte or vent any gas when exposed to a vacuum, in accordance with [MIL-STD-202, method 112](#), test condition C, procedure IIIa.

3.4 Physical testing.

3.4.1 Shock. Shock test shall be as specified in [table II](#).

3.4.3 Resistance to solder heat. The capacitor shall withstand solder dipping of the terminals at 260°C for 10 seconds in accordance with [MIL-STD-202, method 210](#), test condition B. The capacitor shall not be visibly damaged and the electrical characteristics shall not be affected.

3.4.4 Terminal strength. The capacitor terminals shall withstand a 5-pound pull test for 30 seconds in accordance with [MIL-STD-202, method 211](#), test condition A. The capacitor shall not be visibly damaged and the electrical characteristics shall not be affected.

3.4.5 Solderability. The terminations shall be solderable per [MIL-STD-202, method 208](#).

3.4.6 Resistance to solvents. Resistance to solvents shall be as specified in [MIL-STD-202, method 215K](#).

3.5 Recycled, recovered, or environmentally preferable materials. Recycled, recovered, or environmentally preferable materials should be used to the maximum extent possible provided that the material meets or exceeds the operational and maintenance requirements, and promotes economically advantageous life cycle costs.

3.6 Certificate of compliance. A certificate of compliance shall be required from manufacturers requesting to be an approved source of supply.

3.7 Manufacturer eligibility. To be eligible for listing as an approved source of supply a manufacturer shall perform all testing specified herein on a sample of parts agreed upon by the manufacturer and DSCC-VA.

3.8 Marking. Marking shall be in accordance with [MIL-STD-1285](#), except the capacitor shall be marked with the PIN as specified herein ([see 1.2](#)), the manufacturer's name or Commercial and Government Entity (CAGE) code, date lot code and polarity.

3.9 Workmanship. The capacitor shall be uniform in quality and free from any defects that will affect life, serviceability, or appearance.

4. VERIFICATION

4.1 Qualification inspection. Qualification inspection is not required.

4.2 Conformance inspections.

DEFENSE SUPPLY CENTER, COLUMBUS COLUMBUS, OHIO	SIZE A	CODE IDENT NO. 037Z3	DWG NO. 04003
		REV C	PAGE 6

4.2.1 Inspection of product for delivery. Inspection of product for delivery shall consist of dc leakage, capacitance, and ESR.

4.2.2 Certification. The procuring activity, at its discretion, may accept a certificate of compliance for [table II](#) requirements in lieu of performing [table II](#) tests.

5. PACKAGING

5.1 Packaging. For acquisition purposes, the packaging requirements shall be as specified in the contract or order ([see 6.2](#)). When packaging of materiel is to be performed by DoD or in-house contractor personnel, these personnel need to contact the responsible packaging activity to ascertain packaging requirements. Packaging requirements are maintained by the Inventory Control Point's packaging activities within the Military Service or Defense Agency, or within the military service's system commands. Packaging data retrieval is available from the managing Military Department's or Defense Agency's automated packaging files, CD-ROM products, or by contacting the responsible packaging activity.

6. NOTES

(This section contains information of a general or explanatory nature, which may be helpful, but is not mandatory.)

6.1 Intended use. Hybrid capacitors covered by this drawing are intended mainly for use in defense electronic systems, avionics, and weapon systems.

6.2 Ordering data. The contract or purchase order should specify the following:

- a. Complete PIN ([see 1.2](#)).
- b. Requirements for delivery of one copy of the conformance inspection data or certificate of compliance that parts have passed conformance inspection with each shipment of parts by the manufacturer.
- c. Requirements for packaging and packing.
- d. Requirements for notification of change of product to procuring activity, if applicable.

6.3 Tin whisker growth. The use of alloys with tin content greater than 97 percent, by mass, may exhibit tin whisker growth problems after manufacturer. Tin whiskers may occur anytime from a day to years after manufacture and can develop under typical operating conditions, on products that use such materials. Conformal coatings applied over top of a whisker prone surface will not prevent the formation of tin whiskers. Alloys of 3 percent lead, by mass, have been shown to inhibit the growth of tin whiskers. For additional information on this matter, refer to [ASTM-B545](#) (Standard Specification for Electrodeposited Coatings of Tin).

6.4 Replaceability. Capacitors covered by this drawing will replace the same commercial device covered by contractor prepared specification or drawing.

6.5 Similar vendor PIN's. See [table III](#).

6.6 Users of record. Coordination of this document for future revisions is coordinated only with the approved sources of supply and the users of record of this document. Requests to be added as a recorded user of this drawing should be in writing to: Defense Supply Center, Columbus, ATTN: DSCC/VAT, Post Office Box 3990, Columbus, OH 43218-3990 or e-mailed to capacitorfilter@dla.mil also by telephone (614) 692-0563 or DSN 850-0563.

6.7 Approved sources of supply. Approved sources of supply are listed herein. Additional sources will be added as they become available. For assistance in the use of this drawing, contact Defense Supply Center, Columbus, ATTN: DSCC-VAT, Post Office Box 3990, Columbus, OH 43218-3990 or e-mailed to capacitorfilter@dla.mil also by telephone (614) 692-0563 or DSN 850-0563.

DEFENSE SUPPLY CENTER, COLUMBUS COLUMBUS, OHIO	SIZE A	CODE IDENT NO. 037Z3	DWG NO. 04003
		REV C	PAGE 7

TABLE III. Similar vendor PIN.

DSCC PIN 04003- <u>1/</u>	Vendor similar PIN <u>2/</u>	Vendor CAGE	Vendor name and address
01	THQ3010154	06MN5	Evans Capacitor Company 72 Boyd Avenue East Providence, RI 02914-1202
02	THQ3016903		
03	THQ3025543		
04	THQ3035363		
05	THQ3050243		
06	THQ3063123		
07	THQ3080822		
08	THQ3100572		
09	THQ3110452		
10	THQ3125332		

1/ Parts must be purchased to this DSCC PIN to assure all performance and tests are met.

2/ CAUTION: Do not use this number for item acquisition. Items acquired to this number may not satisfy the performance requirements for this drawing.

DEFENSE SUPPLY CENTER, COLUMBUS COLUMBUS, OHIO	SIZE A	CODE IDENT NO. 037Z3	DWG NO. 04003
		REV C	PAGE 8